

Ersatzteilliste - Liste des pièces de rechange - Reservdelislista
Spare Parts List

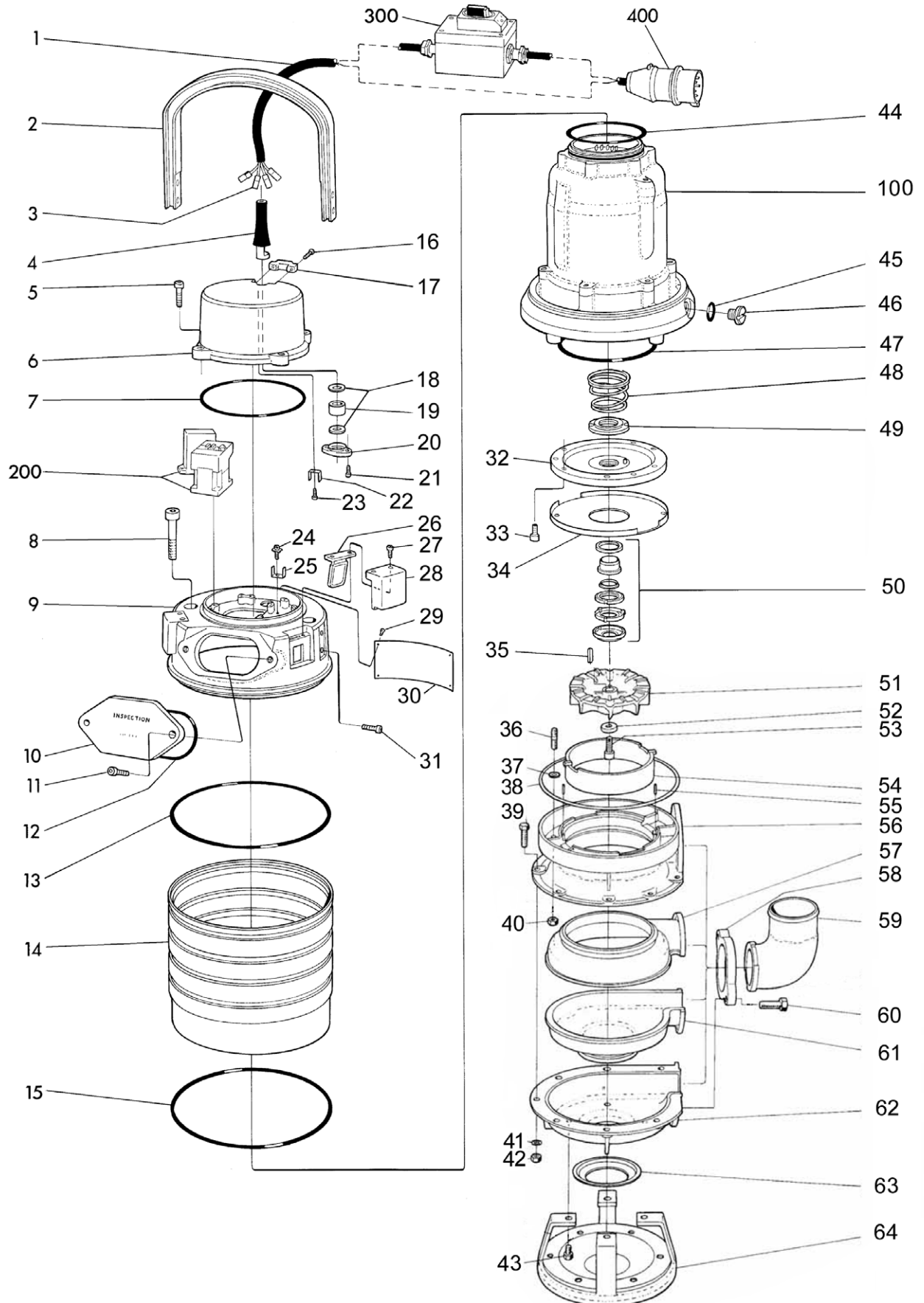

www.grindex.com

SANDY INOX



Motorenhet	Motor unit	Motoreinheit	Moteur complet
------------	------------	--------------	----------------

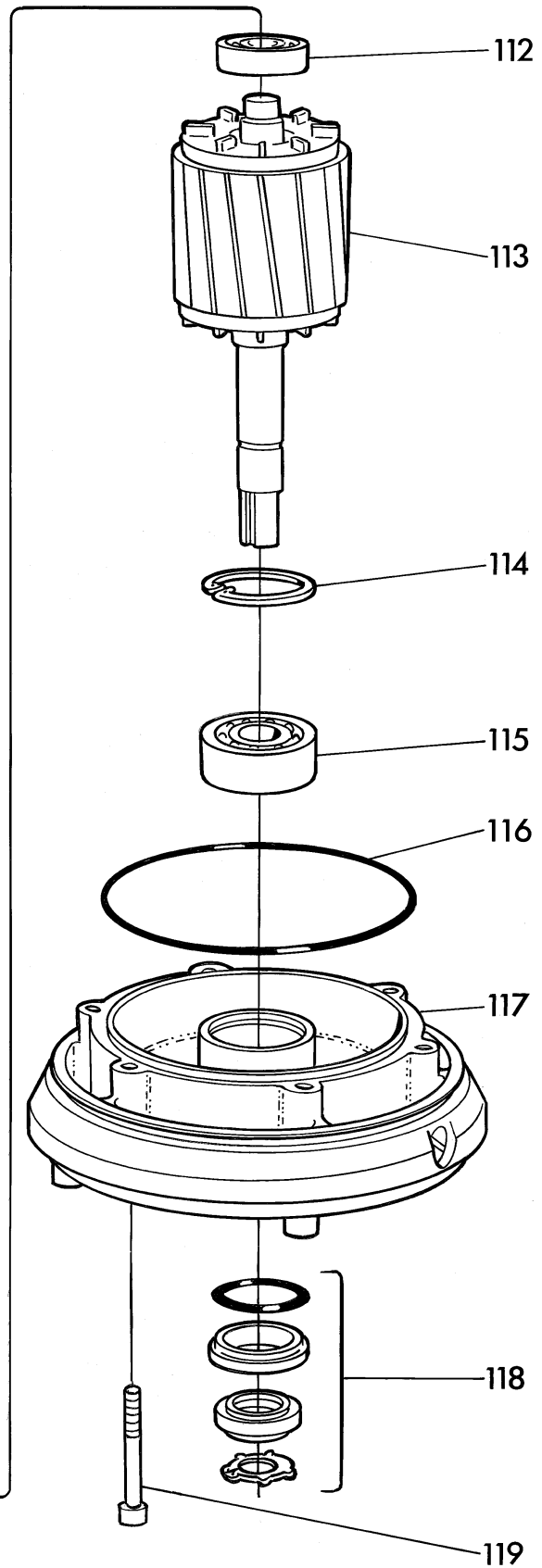
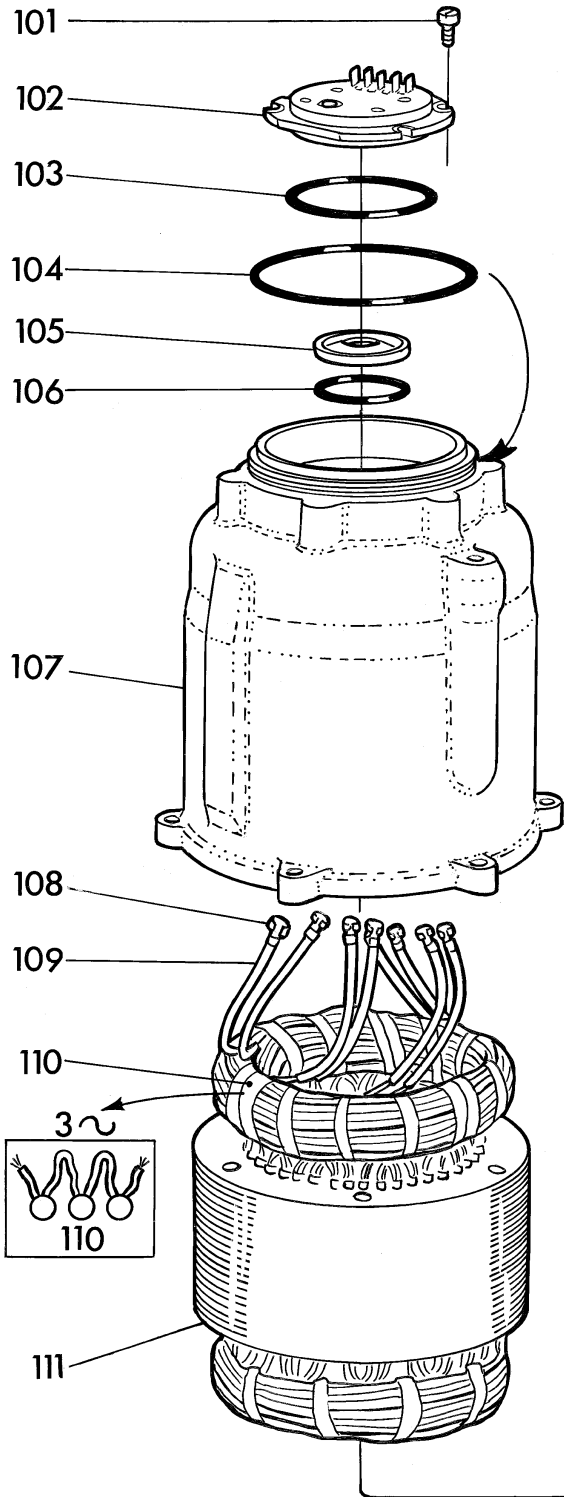

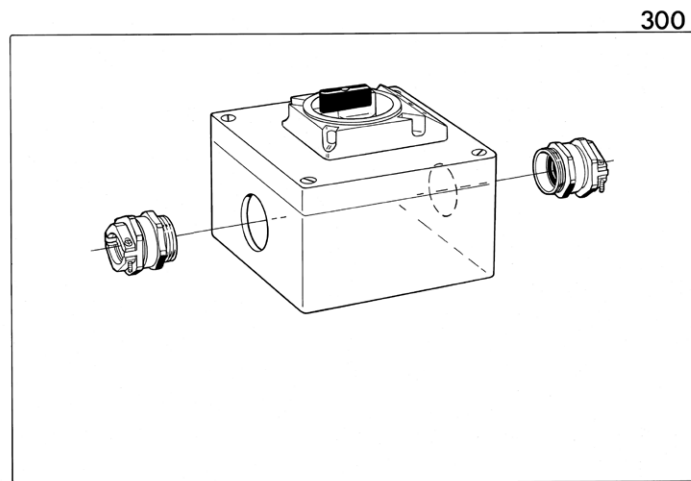
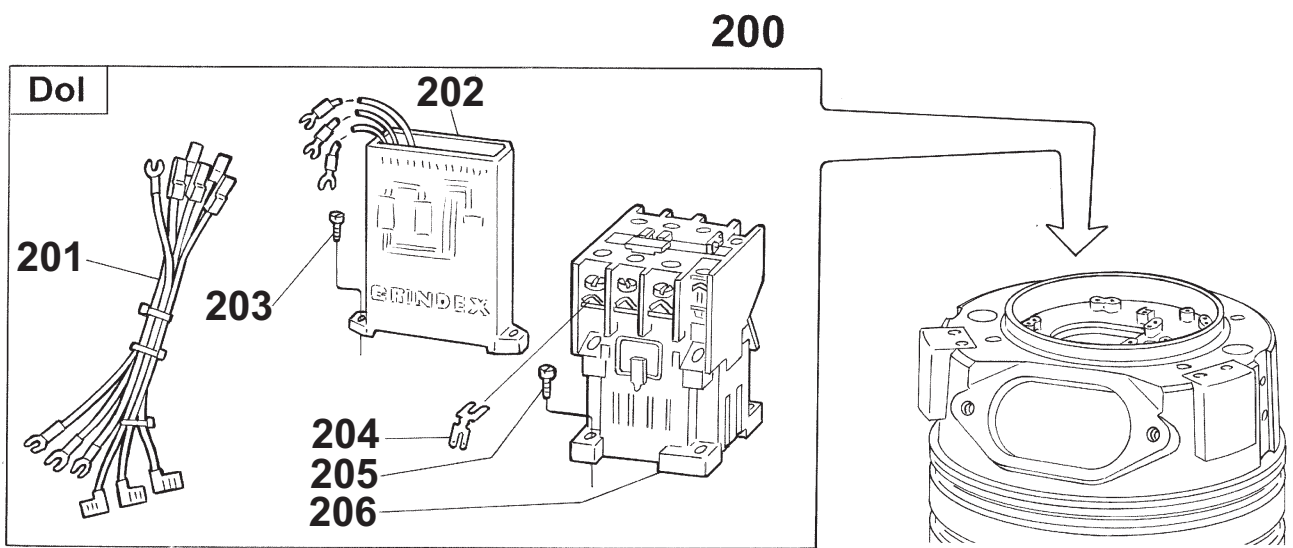

Reservdelslista	Spare Parts List	Ersatzteilliste	Liste des pièces de rechange
Sandy Type 8120.280			

PU Polyurethan Polyurethane Polyurethan Polyuréthane	RF Rostfritt stål Stainless steel Rostfreier Stahl Acier inoxydable	VJ Vitjärn White iron Chromlegerter Hartguss Fonte blanche alliée au chrom
---	--	---

Pos. nr.	Item No.	Detailnr.	Benämning	Denomination	Bezeichnung	Désignation	Antal
Pos-Nr	No. de	Bestell-Nr.					Quantity
repérage	No de pièce						Anzahl
							Nombre
1			Kabel	Cable	Kabel	Câble	1
	131 039		4x2,5mm ² (Subcab Ø12,5-13,5) 20 m		380-575V		
	133 139		4x4mm ² (Subcab Ø16,0-17,0) 20 m		220-230V		
			Gäller upp till 20m längd. Vid annan längd kontakta Grindex.	Refers to length of 20m. For other lengths please contact Grindex.	Bezieht sich auf Länge von 20 Metern. Für andere Längen bitte fragen Sie Grindex.	Concernant longueur de 20 metres. Pour autres longueurs consultez Grindex.	
2	50 721 00		Handtag	Handle	Griff	Poignée	1
3	50 040 03		Flatstiftshylsa	Receptacle	Steckhülse	Clip	4
4			Kabelböjskydd	Cable entry sleeve	Hülse für Kabeleinführung	Douille d'entrée de câble	1
	50 428 01		För Ø12-13.8mm	For Ø12-13.8mm	Für Ø12-13.8mm	Pour Ø12-13.8mm	
	50 428 02		För Ø13,8-15,8mm	For Ø13,8-15,8mm	Für Ø13,8-15,8mm	Pour Ø13,8-15,8 mm	
5	50 021 33		Skruv M8x20	Screw	Schraube	Vis	4
6	50 708 00		Lock	Cover	Deckel	Couvercle	1
7	50 037 22		O-ring 159,3x5,7	O-ring	O-Ring	Anneau torique	1
8	50 023 08		Skruv M 12x70	Screw	Schraube	Vis	2
9	50 737 00		Överdel	Main cover	Hauptdeckel	Couvercle principal	1
10	50 724 00		Inspektionslock	Inspection cover	Inspektionsdeckel	Couvercle inspection	1
11	50 022 16		Skruv M10x30	Screw	Schraube	Vis	2
12	50 037 23		O-ring 104,1x5,34	O-ring	O-Ring	Anneau torique	1
13	50 037 24		O-ring 259,3x3	O-ring	O-Ring	Anneau torique	1
14	50 064 03		Mantel	Outer casing	Aussenmantel	Enveloppe extérieure	1
15	50 037 68		O-ring 249.3x5,7	O-ring	O-Ring	Anneau torique	1
16	50 019 05		Skruv M5x18	Screw	Schraube	Vis	2
17	50 725 00		Kabelavlastning	Cable clamp	Zugentlastung	Collier	1
18			Tättningsbricka, för kabel:	Washer, for cable:	Gummidichtung, für Kabel:	Manchon, pour câble:	2
	50 016 14		Ø12-14 mm (Ø0.47-0.55 in)		220V - 575V		
	50 016 15		Ø14-16mm (Ø0.55-0.63in)		220-230V		
19			Gummikuts, för kabel:	Rubber seal, for cable:	Gummidichtung, für Kabel:	Manchon, pour câble	1
	50 015 01		Ø12-14 mm (Ø0.47-0.55 in)		220V - 575V		
	50 015 02		Ø14-16mm (Ø0.55-0.63in)		220-230V		
20	50 726 00		Införingsfläns	Cable entry flange	Kabeleinführungsflansch	Bride d'entrée de câble	1
21	50 019 05		Skruv M5x18	Screw	Schraube	Vis	2
22	50 119 00		Flatstiftsbleck	Tab	Flachstecker	Ian guette	1
23	50 018 01		Skruv M4x8	Screw	Schraube	Vis	1
24	133 525		Skruv	Screw	Schraube	Vis	1

Item No.	Part No.	Benämning	Denomination	Bezeichnung	Désignation	Quantity
25	50 119 00	Flatstiftsbleck	Tab	Flachstecker	Ian guette	1
26	50 013 00	Ventil	Valve	Ventil	Soupape	2
27	50 019 05	Skruv M5x18	Screw	Schraube	Vis	4
28	50 722 00	Ventillock	Valve cover	Ventildeckel	Couvercle de soupape	2
29	410 393	Nit	Rivet	Niet	Rivet	2
30		Dataskylt	Data plate	Datenschild	Plaque signal	1
	50 907 02	(EU)				
	50 907 03	(US)				
31	50 021 30	Skruv M8x25	Screw	Schraube	Vis	4
32	50 715 00	Oljehusbotten	Oil housing bottom	Ölgehäuseboden	Fond de carter à huile	1
33	50 021 32	Skruv M8x16	Screw	Schraube	Vis	6
34	50 703 00	Styrplåt	Guide plate	Steuerblech	Plaque de recouvrement	1
35	50 205 03	Plattkil 5x5x32	Key 5x5x32	Keil 5x5x32	Clavette 5x5x32	1
36	50 022 20	Pinnskruv	Stud	Stiftschraube	Goujon	4
37	130 896	Packning	Seal	Dichtung	Joint	4
38	131 544	Packning	Gasket	Dichtung	Joint	1
39	50 022 15	Skruv M10x35	Screw	Schraube	Vis	8
40	50 022 22	Mutter M10	Nut	Mutter	Ecrou	4
41	50 022 26	Bricka	Washer	Scheibe	Rondelle	8
42	50 022 22	Mutter M10	Nut	Mutter	Ecrou	8
43	50 023 09	Skruv M12x25	Screw	Schraube	Vis	4
44	50 037 07	O-ring 117.5x5.34	O-ring	O-Ring	Anneau torique	1
45	50 037 13	O-ring 12.37x2.62	O-ring	O-Ring	Anneau torique	1
46	50 705 00	Oljeskruv	Oil screw	Ölschraube	Vis d'huile	1
47	50 037 25	O-ring 156.0x3.0	O-ring	O-Ring	Anneau torique	1
48	50 559 01	Fjäder	Spring	Feder	Ressort	1
49	50 740 00	Tryckplatta	Thrust plate	Druckscheibe	Rondelle	1
50	50 789 00	Axeltätningssats, undre	Shaft seal kit, lower	Wellendichtung, unt.,Satz	Joint mécanique, inf. jeu	1
51		Pumphjul	Impeller	Laufrad	Roue	1
	50Hz			60Hz		
	50 805 00	Ø125mm (Ø4.92") RF		50 805 01	Ø105mm (Ø4,13") RF	
52	50 022 27	Bricka	Washer	Scheibe	Rondelle	1
53	133 148	Skruv	Screw	Schraube	Vis	1
54	50 823 00	Slitring	Wear ring	Schleissring	Anneau d'usure	1
55	50 739 00	Cylinderpinne	Pin	Zylinderstift	Goupille	2
56	50 717 00	Pumphus, övre	Pump housing, up.	Pumpengehäuse,ob.	Corps de pompe, sup.	1
57	132 041	Inlägg, övre	Lining, upper	Einlage, ob	Jupe, sup	1
58	50 727 00	Överfall	Clamp	Ueberwurf	Collier	1
59		Tryckanslutning	Discharge conn.	Druckanschluss	Coude de refoulement	1
	50 735 00	DN 75, Hose 3"	50 736 00	DN100, Hose 4"		
	50 735 01	DN 75, ISO G3A outer	50 736 01	DN100, ISO G4A outer		
	50 735 02	DN 75, NPT 3-8 outer	50 736 02	DN100, NPT 4-8 outer		

Item No.	Part No.	Benämning	Denomination	Bezeichnung	Désignation	Quantity
60	50 024 07	Skruv M 16x40	Screw	Schraube	Vis	2
61	132 042	Inlägg, undre	Lining, lower	Einlage, unt.	Jupe inf.	1
62	50 718 00	Pumphus, undre	Pump housing, low.	Pumpengehäuse, unt.	Corps de pompe, inf.	1
63	131 554	Fästring	Holder ring	Haltring	Anneau de serrage	1
64	50 818 00	Stödenhet	Stand	Ständer	Pied	1
100		Motorenhet	Motor unit	Motoreinheit	Moteur complet	
101	50 021 31	Skruv M 8x10	Screw	Schraube	Vis	4
102	50 009 00	Kopplingsplint	Terminal board	Klemmenbrett	Plaque à bornes	1
103	50 037 27	O-ring 74.61x3.53	O-ring	O-Ring	Anneau torique	1
104	50 037 09	O-ring 119.5x3.0	O-ring	O-Ring	Anneau torique	1
105	140 326	Täcklock	Protection cover	Schutzdeckel	Couvercle de protecteur	1
106	50 037 26	O-ring 47.63x3.53	O-ring	O-Ring	Anneau torique	1
107	50 762 00	Statorhus	Stator housing	Statorgehäuse	Logement de stator	1
108		Flatstift/ serieskarv	Solderless lug/ joining tube	Flachsteckkontakt/ Verbindung	Pris contact plat/ connexion	
	50 040 03	Flatstift	Solderless lug	Flachsteckkontakt	Pris contact plat	3-9
	410 034	Serieskarv 460V endast 9-ledare	Joining tube 460V only 9-leads	Verbindung 460V nur 9-Leiter	Connexion 460V 9-conducteurs seules.	3
109	50 079 01	Systoflexrör 40mm	Insulating tube	Isolierschlauch	Gaine isolante	3
110	50 039 01	Termokontakt	Thermal contact	Thermokontakt	Contact thermique	1
111		Stator	Stator	Stator	Stator	1
	50 Hz		60 Hz			
	50 306 05	220/380-415V	50 306 14	230/460V 9-leads		
	50 306 09	500-550V D	50 306 16	575V D		
112	140 337	Kullager, övre	Ball bearing, upper	Kugellager, oberes	Roulement à billes, sup.	1
113	50 731 00	Rotorenhet	Rotor unit	Rotoreinheit	Rotor complet	1
114	140 064	Låsring	Circlip	Nutring	Circlip	1
115	140 059	Kullager, nedre	Ball bearing, lower	Kugellager, unteres	Roulement à billes, inf.	1
116	50 037 17	O-ring 183.5x3.0	O-ring	O-Ring	Anneau torique	1
117	50 714 00	Lagerhållare	Bearing holder	Lagerhalter	Logement de roulement	1
118	50 534 00	Axeltätningssats, övre	Shaft seal kit, upper	Wellendichtung, ob.,Satz	Joint mécanique, sup. jeu	1
119	50 021 27	Skruv M 8x75	Screw	Schraube	Vis	6
200		Startutrustning	Starter Kit	Starter-Installationssatz	Kit De Démarreur	
	50 Hz		60 Hz			
	50 820 10	380-415V / 50Hz DOL		50 820 16	575V / 60Hz DOL	
	50 820 12	500V / 50Hz DOL		50 820 15	460V / 60Hz DOL	
201	50 035 01	Kabelhärva	Conductors, set	Leitungen, Satz	Conducteurs, compl.	1
202		Motorskydd	Motor protector	Motorschutzschalter	Disjoncteur	1
	50 Hz		60 Hz			
	50 034 01	340-460V	50 034 04	340-460V		
	50 034 02	500-575V	50 034 05	500-575V		
203	50 018 00	Skruv M4x12	Screw	Schraube	Vis	2
204	50 120 01	Flatstiftsbleck	Tab	Flachstecker	Ian guette	3
205	50 018 00	Skruv M4x12	Screw	Schraube	Vis	2
206	DOL	Kontaktor	Contacteur	Kontaktor	Contacteur	(1)
	50 Hz		60 Hz			
	410 160	380-415V	410 394	460V		
	410 395	500-550V	410 395	575V		

Item No.	Part No.	Benämning	Denomination	Bezeichnung	Désignation	Quantity
300		Fasväxlare	Phase shifter	Phasenwechsler	Inverseur de phase	(1)
	0-16A	0-22A				
	Ø6-13mm	Ø9-17mm				
	50 102 00	50 102 01				
400		Europahandske	Euro plug	Euro-Verdinder	Euro connecteur	(1)
	50 100 01	CEE 432-6 (380-400V/50Hz)				
	50 100 10	CEE 316-7 (500V/50Hz)				
	50 100 11	CEE 332-7 (500V/50Hz)				
	50 085 07	O-ringsats, bestående av:	Set of O-rings comprising:	O-Ringsatz, bestehend aus:	Anneaux toriques, jeu comprenant:	1
7	50 037 22	(1)	45	50 037 13 (1)		
12	50 037 23	(1)	47	50 037 25 (1)		
13	50 037 24	(1)	103	50 037 27 (1)		
15	50 037 68	(1)	104	50 037 09 (1)		
37	130 896	(4)	106	50 037 26 (1)		
38	131 544	(1)	116	50 037 17 (1)		
44	50 037 07	(1)				
		Olja	Oil	Öl	Huile	0.40L
		Vitolja	White oil	Weißöl	Huile cristalline	
		Viskositet ISO VG 15	Viscosity ISO VG 15	Viskosität ISO VG 15	Viscosité ISO VG 15	

Specifications can be changed without notice.

