

SH 1000

Type 1000 m - 100 mm

HÜDIG-Hose reel

Application

In agriculture - landscaping – industry

- 🔧 Agricultural irrigation
- 🔧 Slurry irrigation
- 🔧 Fruit and vegetable growing
- 🔧 Landscaping

Standard Features

- 🔧 Hose reel for holding 1000 m - Ø 100 mm flat hose (10 lengths of 100 m each incl. Storz 100 couplings with clamping ring)
- 🔧 Drive on both sides via generously dimensioned hydraulic motors
- 🔧 Standard external one-man operation via an operating handle for activating or deactivating the hydraulic motor in the working area
- 🔧 Mounting quiver in the centre tube for mounting Storz A couplings
- 🔧 Fully galvanised design of the support frame and the reel tube for optimum corrosion resistance even in harsh applications
- 🔧 4 support feet to safely park the hose reel
- 🔧 Category 2 three-point linkage for attachment to the front or rear hydraulics of the tractor
- 🔧 Tool-free reel change for using additional reels with a support frame
- 🔧 SK elbow holder



Fig.: SH 1000 fully equipped with optional accessories

Function

HÜDIG has set standards in the development of irrigation machines. For more than 100 years now, experience from agricultural irrigation has been utilised for the development and improvement of our products. The hose reel developed for irrigation applications simplifies the supply of water to the irrigation machine many times over compared to the laying of quick-coupling pipes. The hydraulically driven hose reel lays the hose in the desired position and picks it up again reliably once irrigation is complete. It can be mounted in the front and rear hydraulics as well as in the front loader with the aid of an adapter. Only a double-acting control valve is required for the drive. Various options round off the convenient supply line installation.

Special Features

- 🔧 Subdivision of the reel into max. 5 chambers by means of plug-in drum segments
- 🔧 Attachment in front loader possible via separate adapter
- 🔧 Separate change reel to extend the required hose capacity
- 🔧 Hose guide arm for guiding the hose when laying down or winding up.
- 🔧 Remote control of the boom via radio remote control
- 🔧 SK elbow holder

Components



Drum Sections

The reel segments can be used to divide the reel into up to 5 separate chambers, e.g. to carry different lengths of hose sorted by length. These segments are designed as segment halves and can therefore be easily retrofitted in sets. A maximum of 4 sets of reel segments can be installed.



Hose Guide Outrigger

The hose guide boom enables the flat hose to be laid precisely along a tractor track, field path, etc. The hose is guided through a cage fitted with protective rollers. The hose is guided through a basket fitted with protective rollers. As standard, the swivelling cylinder of the boom is controlled via a further double-acting control valve. The boom arm can be conveniently folded in for road travel.



Remote Control for Outriggers

Two double-acting control valves are required for trouble-free operation of the hose reel incl. hose guide boom. With the aid of the radio remote control, convenient operation is also possible if the tractor only has one double-acting control valve and an unpressurised return line. An electrically controlled changeover valve supplies both the hydraulic motor of the reel and the swivelling cylinder of the boom.



Interchangeable Reel

If the hose capacity of a hose reel is not sufficient, it can be extended with an additional, individual reel. The reel can be changed in the support frame without tools. The octagonal geometry ensures that the loose reel stands securely even without a support frame.

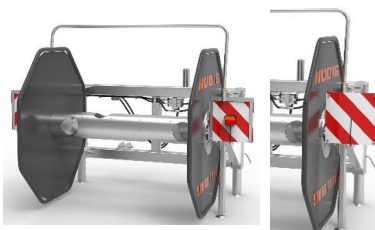

Lighting equipment

A lighting system including warning signs can be installed for the rear attachment. Thanks to a simple plug-in system, the warning signs with lighting can be used for both front and rear mounting.

Dimensions

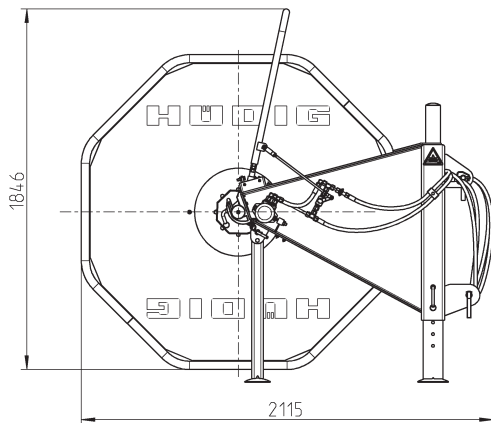
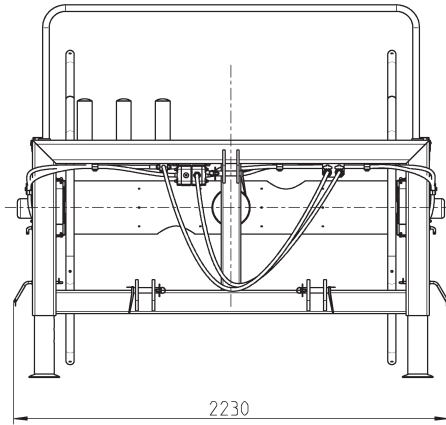

Technical Data

Parameter	Unit	Value
Length	mm	2.050
Width	mm	2.200
Height	mm	1.900
Net weight	kg	580
Max. capacity	-	1000 m – Ø 100 mm hose
Weight incl. hose ¹⁾	kg	1.650
Three-point mounting	-	Category 2

1) Depending on the hose size and number of hose couplings